

# HRH0828RE

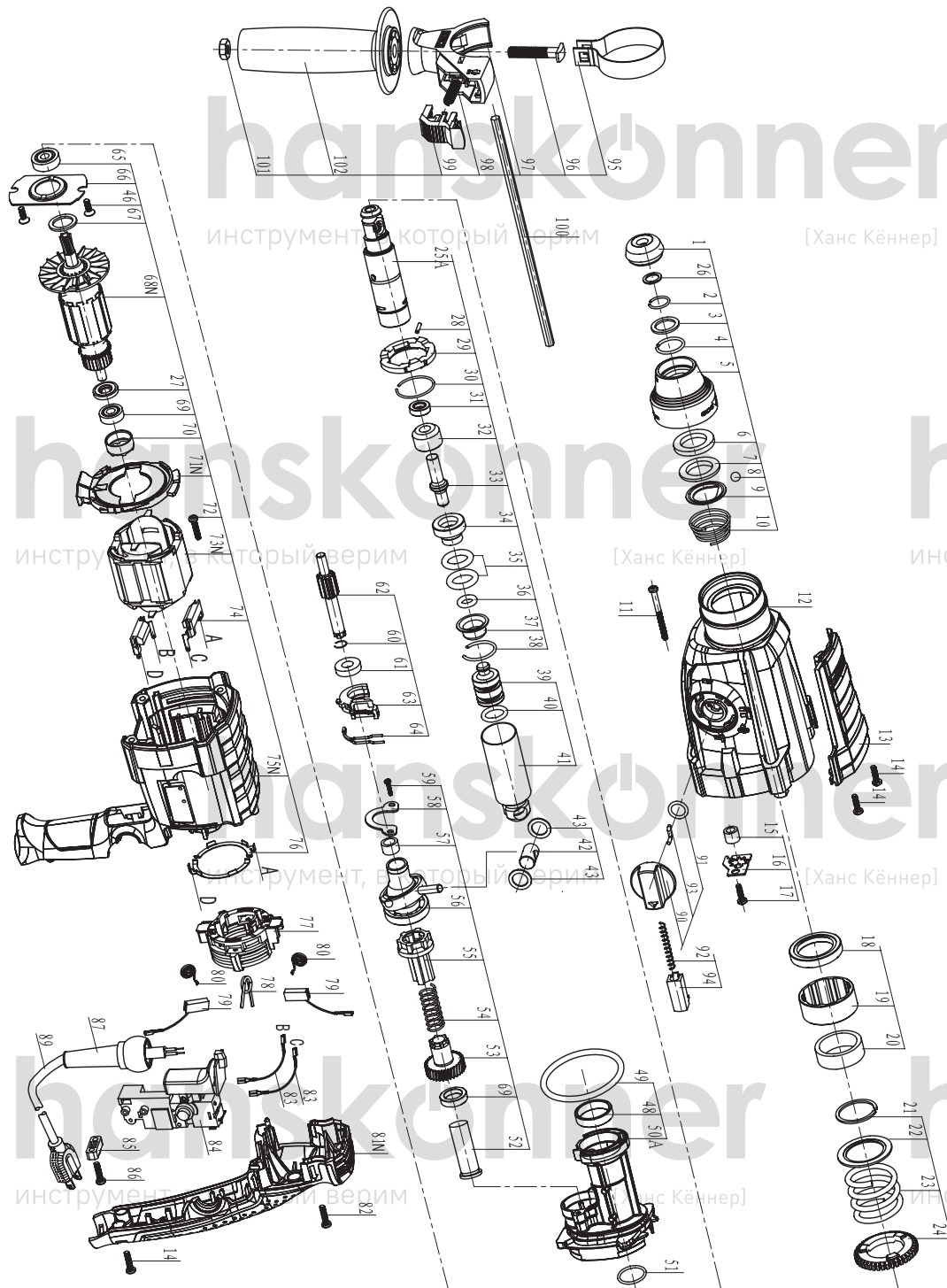

NO.	DESCRIPTION	NO.	DESCRIPTION
1	DUST CAP	53	38 DENS SLANTING GEAR
2	RING SPRING OF DUST CAP 14X1.5	54	CLUTCH SPRING
3	WASHER FOR DUST CAP 16X22X1	55	CLUTCH
4	RING SPRING OF DUST CAP 19X2	56	ASWAY-POLED BEARING
5	LOCKING SLEEVE	57	NEEDLE BEARING HK0908
6	WASHER FOR DUST CAP 21X32X4	58	ASWAY-POLED BEARING PRESSURE BOARD
7	WASHER C24.8X30.6X1	59	M5X16 CREW
8	STELL BALLC7.14	60	CIRCLIP
9	RING SPRING FLORIATE WASHER	61	699 BEARING
10	TOWER-SHAPED SCREW	62	MID-AXIAL
11	ST4.1X45SELF-TAPPING BOLT	63	MODEL SELECTOR FORK
12	GEAX BOX	64	MODEL SELECTOR FORK SPRING
13	GEAX BOX COVER	65	609BEARING
14	ST4.2X11SELF-TAPPING BOLT	66	609BEARING PRESSURE BOARD
15	HK0709 NEEDLE BEARING	68N	ARMATURE
16	NINE DENS WASHER	69	607BEARING
17	ST4.2X11 SELF-TAPPING BOLT	70	BEARING COVER
18	OIL SEAL 30X41X7	71N	BOARD AGAINST WIND
19	HK3012 BEARING SLEEVE	72	ST3.5X16 SELF-TAPPING BOLT
20	HK3012 ROLL PIN	73N	STATOR
21	OUTER FLATE RING SPRING OF ROTOR SLEEVE	74	INDUCTANCE
22	DRILL COVER WASHER	75N	SHELL
23	DRILL COVER SPRING	76	SPRING PIECE
24	40 DENS GEAR	77	BRACKET OF ELECTRIC BRUSH
25A	DRILL COVER	78	SPRING
26	WASHER	79	ELECTRIC BRUSH
27	CONNECTION DRILL COVER	80	SPRING
28	POSITION-KEY 2.5X12	81N	BACK COVER
29	POSITION-LIMITED RING	82	ST4.1X16SELF-TAPPING BOLT
30	OUTER RING SPRING OF ROTOR SLEEVE	83	ROTOR INSERT LINE 120MM
31	OIL SEAL 9X16X5	84	SWITCH
32	POSITION-LIMITED SLEEVE OF SPINDLE	85	PRESS CALE BOARD
33	SPINDLE	86	ST3.9X15 SELF-TAPPING BOLT
34	SPINDLE SETS	87	CABLE COVER
35	SPINDLE SETS O-RING 16.2X4.5	89	CABLE 2X0.75MM
36	POSITION-LIMITED O-RING 9.6X3.5	90	MODEL SELECTOR KNOB
37	POSITION-LIMITED COVER	91	MODEL SELECTOR O-RING 11X2.5
38	STELL WIRE SPRING 27.5X1.5	92	MODEL SELECTOR SPRING 5.8X44
39	PISTON	93	MODEL SELECTOR IRON CORE
40	PISTONO-RING 15X3	94	MODEL SELECTOR RED KNOB
41	CYLINDER	95	HANDLE STEEL RING
42	CYLINDER KEY	96	T BOLT
43	CYLINDER WASHER	97	HANDLE SEAT
48	BRACKET SLEEVE	98	DEPTH GUAGE LOCK SPRING
49	BRACKET O RING	99	DEPTH GUAGE LOCK
50A	BRACKET	100	DEPTH GUAGE
51	O-RING 23.8X22	101	M8 BOLT
52	GEAR FIXED	102	ASSISTANT HANDLE